



Presses & Automation – Since 1975

Instruction Manual Decoiler AZ-DH





Azimuth Hydraulic Decoilers Instruction Manual

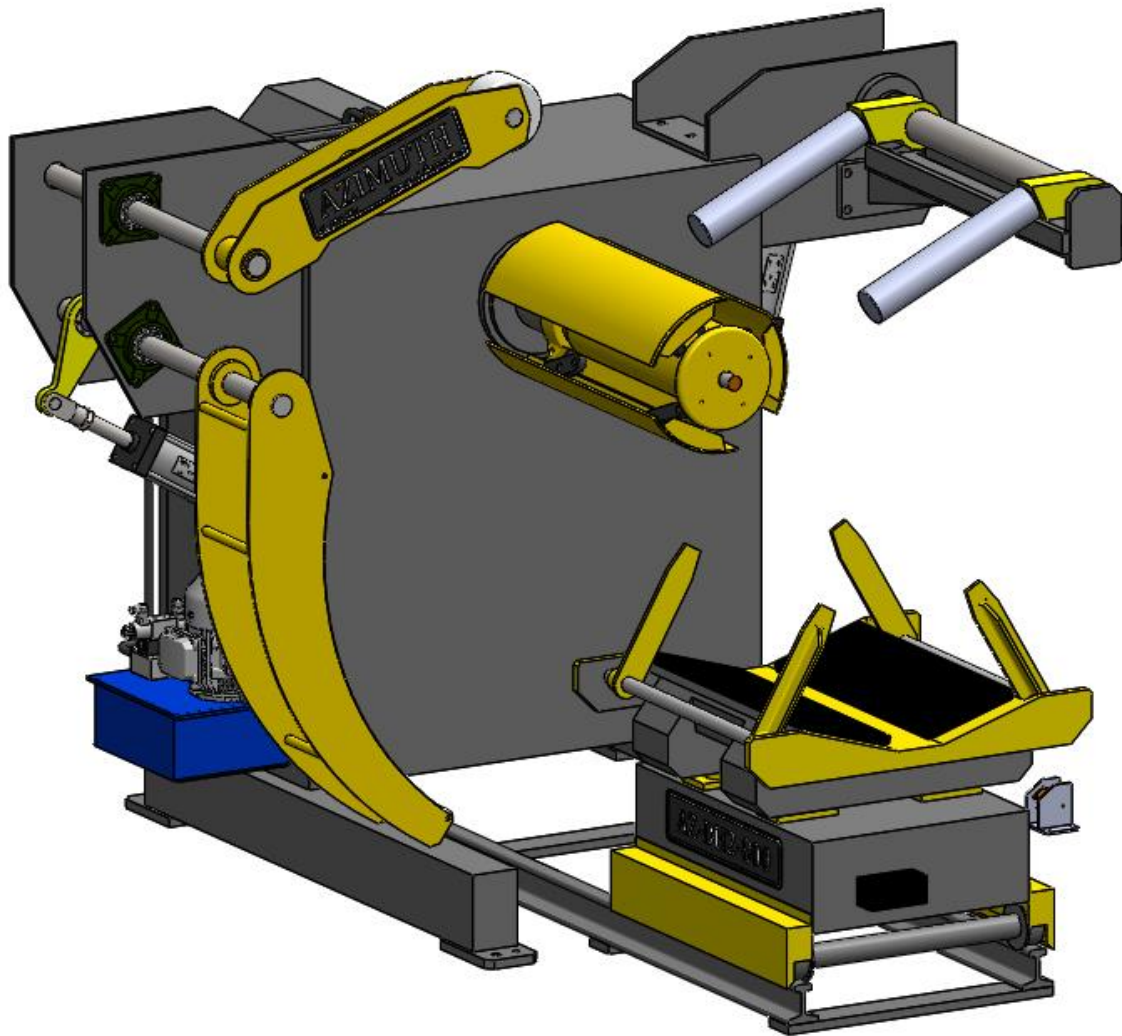



Table of Contents

1. Word of Caution	5
2. Installation	7
2.1. Decoiler alignment and leveling	7
2.2. Coil cart alignment and leveling	8
2.3. Hydraulic and air lines connections	8
5. Maintenance	9
a. Machine routine maintenance needs	9
b. Machine troubleshooting instructions.....	10
APPENDIX.....	11
APPENDIX I: AZ-DH DRAWING	11



1. Word of Caution

- ⚠ This machine is rated for 208V/60Hz and 480V/60Hz in star configuration. Make sure to properly connect the machine.
- ⚠ Before using the machine with material, make sure to perform a visual inspection and try to cycle it 5 times to verify that nothing has been damaged during transport (guarding system, etc.)
- ⚠ Never operate this machine until you've read & understood that this machine is dangerous. Placing your hands or any part of your body in this machine could lead to serious injuries or death. Warnings are posted around the machine for this purpose.
- ⚠ Never operate this machine without the use of a guard or safety device that will always protect you from injuries.
- ⚠ Never work on this machine unless the power is turned off and locked.
- ⚠ Never operate the equipment in teams of two or more
- ⚠ Never leave the workspace during the equipment operation
- ⚠ Follow the lockout procedures when leaving or servicing the equipment

***** Never put your hands in the machine unless the power is turned off and locked out ****



The following general conditions must be followed.

- Check the machine and make sure that there is no damage when taking delivery of your machine. Please ask your dealer for replacement of shipping damage within 7 days starting the date of purchase, replacement requests are invalid after 7 days.
- Please check whether the accessories are missing while delivery of your machine. If there are any missing parts, please ask your dealer for the provision of the parts in question within 7 days from the date of purchase. Request you make after 7 days will not be considered.
- Make sure your machine is grounded and there are no voltage fluctuations on power supply.
- Failures caused by use of improper power connections are not covered by warranty of your machine. Repair of such failures will bring you financial burden.
- Do not try to attach external parts to each other's slots or their own slot the wrong way. Do all connections while the machine is off, do not try to attach or detach any parts while the machine is running.
- Do not interfere with software on the machine. Any modification to the software can be done only if Azimuth approves the request. Otherwise, it will cause your machine to be out of warranty.
- Make sure all connections to the machine are correctly made.
- Machine work surface must be flat, non-slip and solid.
- If our machine works with another machine than Azimuth ones, the manufacturer is not liable for any damage or work loss due to shock, moving around or vibrations in the event of overload of the other machine.
- Loading capacity of the machine must not be exceeded. Work overload will damage the machine and all components rotating (follow approval drawings and quote dimension specifications).
- Make sure the machine is working as shown by the technical service during installation.
- Only use our machines for sheet materials, our machines are designed for uncoiling, feeding and cutting sheet metals. They are not suitable for round or rectangle profiled materials.
- Do not modify the equipment at will. Azimuth is not responsible for damage or accident caused by unauthorized components or modifications.



2. Installation

This section covers the mechanical set-up of the hydraulic decoiler (AZ-DHX). Please make sure to fully understand these instructions before attempting to make mechanical adjustments to the machine. All hydraulic decoilers drawings are presented in Appendix I. Dimensions and specifications may vary depending on orders. Please refer to the approval drawings sent during the project. The instructions below will guide you through the machine installation. Azimuth installation staff are providing support for this manner.

2.1. Decoiler alignment and leveling

All components of the line such as decoiler, straightener, feeder, die and press should be exactly parallel to each other. Precision lasers are used to meet this requirement during installation. If the feed line is not properly aligned, the sheet material may slide to the sides and get damaged or stick inside the die and damage the equipment. Follow the recommended distance between the decoiler and the feeder shown in the approval drawing of your feedline. Creating the proper loop for the material will help the automatic sequence and material stress.

To level the decoiler correctly, use the screws located on the feet of the machine. Make sure to secure the equipment with anchors afterward.

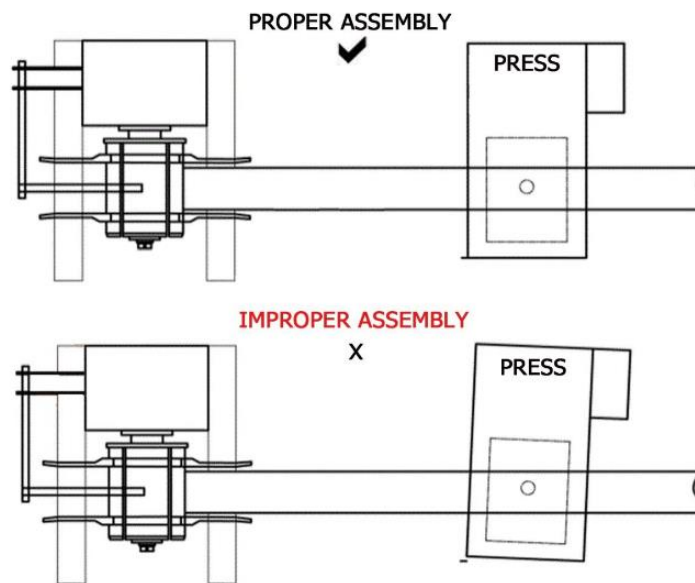

Figure 1 : Feedline alignment



2.2. Coils cart alignment and leveling

The coil cart should align precisely with the decoiler mandrel using precision lasers. Utilizing a coil on the cart ensures proper alignment, which prevents sliding and equipment damage. To level the cart correctly, adjust the screws located on the feet of the machine. Confirm that the coil reaches the correct position before securing everything.

2.3. Hydraulic and air lines connections

All hydraulic pipes are marked with a number or letter depending on their position on the hydraulic station. Please connect the hydraulics lines with the matching numbers or letters. The working pressure should be 14 MPa and the maximum pressure is 17 MPa.



Figure 2 : Hydraulic lines connection

Before starting the hydraulic station, follow the steps below :

1. Fill the hydraulic station with #68 anti-wear hydraulic oil. Ensure that all lines are correctly bled
2. The motor needs to rotate clockwise when viewed from the back of the motor
3. When the hydraulic station is turned on, it should be adjusted to low pressure first and then adjusted to working pressure after the test are normal
4. Do regular inspections and maintenance every 6 months

All air lines should be connected correctly upon delivery. The main line connects via the air entry from the AZ-SF-XXXX feeder with the decoiler. If sold separately, connect the decoiler directly to the facility system. Maintain air cylinder pressure between 0.4 and 0.6 MPa.



5. Maintenance

Always ensure the machine is stopped and lockout procedures are followed before conducting any servicing. Maintenance requirements and delays may vary depending on the system environment and continuous operation duration. Please refer to the instructions provided by Azimuth trainers for this matter.

a. Machine routine maintenance needs

- The condition in the air system (dryer/lubricator), daily oil checks should be made, and the water must be emptied. Verify if there is a leak and the pressure is normal. Air pressure should be maintained at 0.5 MPa.
- Electrical components and machine functionality (loop sensor, e-stop, valves, oil pressure, brake and all switches) should be checked daily to ensure the proper functionality of the system. Components should be kept clean to ensure long longevity.
- Before working with the machine, operators must check all the working parts, should do the checks against the possibility of loosening and dismantling due to the vibrations occurring during feeding. Uncommon sounds are a good sign of malfunction.
- Lubricate guidance rollers and screw shafts regularly.
- Periodically lubricate all the bearings and gears according to the maintenance chart.
- Periodically lubricate the expansion mandrel and pressure arm cylinder according to the maintenance chart.
- Lubricate and check the tension of the mandrel and coil cart chain. Chains should be moving forward and backward equivalent to the width of a link.
- Periodically check if the photoelectric sensor is working well and clean the glass surface.
- Oil tank and hose must be checked weekly for any leaks or malfunction. We suggest checking the oil quality at the same time. Make an oil change according to the maintenance chart.
- If the machine is not in use, please power and cycle the system once a week.
- General maintenance and checks on the machine are mainly focused on abrasion and moving parts. For further details on the replacement part, go to Appendix I.



Table 1: Routine maintenance needs

Parts	Daily	Weekly	Monthly	Biannual
Conditioning oil control	✓			
Guidance rollers		✓		
Lubrication of bearings		✓		
Lubrification of expansion mandrel		✓		
Lubrification & tension of chains			✓	
Oil tank and hose control		✓		
Oil change	✓			
General maintenance and checks of the machine				✓

b. Machine troubleshooting instructions

For any requests regarding troubleshooting or issues with the machine, please contact directly Azimuth following the contact information provided on the website.



APPENDIX

APPENDIX I: AZ-DH DRAWING

In this appendix, you will find the spare parts for all the AZ-DH decoiler models. Use this template for part numbers when ordering. Also, always mentioned the machine serial number. This assists Azimuth crew members in tracking parts according to the specific configuration of your machine.

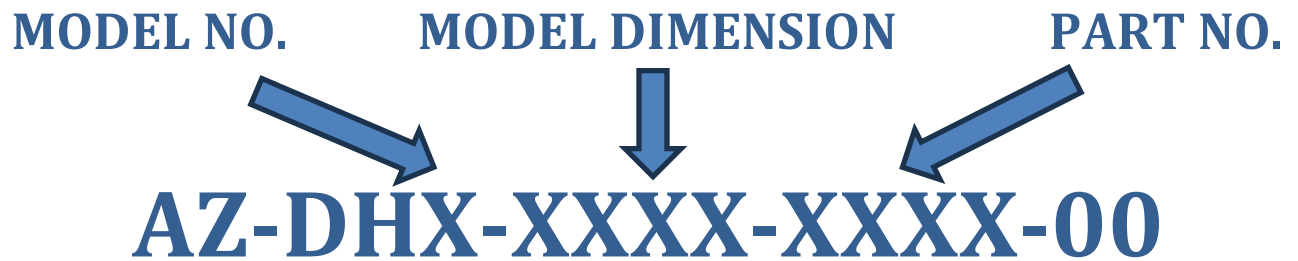

ITEM NO.	PART NO.	DESCRIPTION	QTY.
1	AZ-DHX-XXXX-1000-00	FRAME ASSEMBLY	1
2	AZ-DHX-XXXX-2000-00	MANDREL SHAFT ASSEMBLY	1
3	AZ-DHX-XXXX-3000-00	MOTOR ASSEMBLY	1
4	AZ-DHX-XXXX-4000-00	MANDREL EXPANSION ASSEMBLY	1
5	AZ-DHX-XXXX-5000-00	COIL CART ASSEMBLY	1
6	AZ-DHX-XXXX-6000-00	BRAKE ASSEMBLY	1
7	AZ-DHX-XXXX-7100-00	PRESSURE ARM ASSEMBLY	1
8	AZ-DHX-XXXX-7200-00	SWING ARM ASSEMBLY	1
9	AZ-DHX-XXXX-7300-00	COIL KEEPERS ASSEMBLY	1
10	AZ-DHX-XXXX-8000-00	OIL TANK ASSEMBLY	1
11	AZ-DHX-XXXX-1400-00	GUARDING PARTS	1

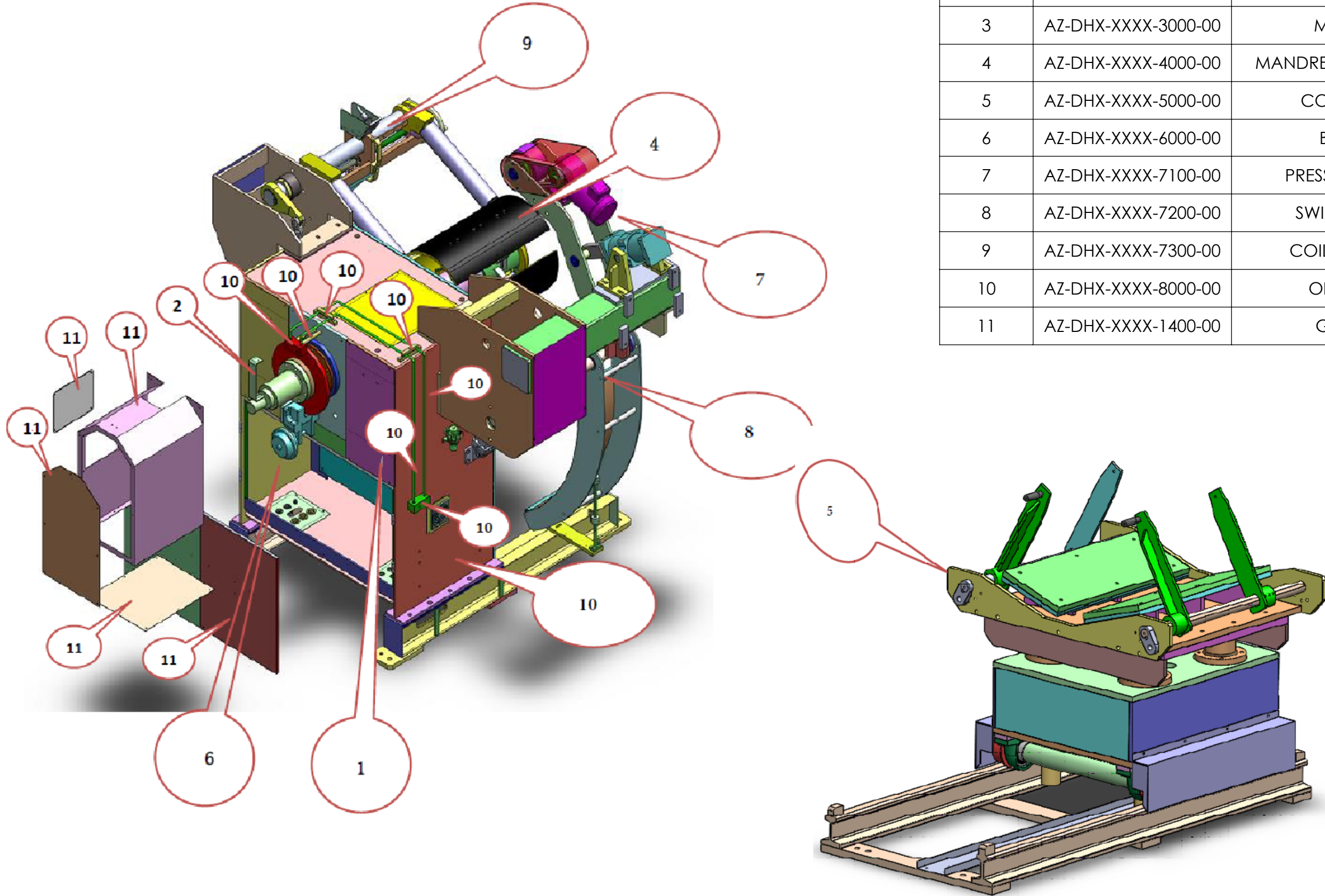

DESCRIPTION
HYDRAULIC DECOILER ASSEMBLY

PART NO
AZ-DHX-XXXX-XXXX-XX

DRAWN BY CHARLES LEFEBVRE	SCALE 4:1
DATE 2025-02-20	MATERIAL
RAW MATERIAL	QTY
TREATMENT	WEIGHT

AZIMUTH
 Azimuth Machinery Ltd
 T 450 532 6080
 F 450 532 6081
 www.azimuthpress.com
 6042 Rte. 132, Ste-Catherine
 QC, Canada, J5C 1K6

PROPRIETARY AND CONFIDENTIAL
 THE INFORMATION CONTAINED IN THIS DRAWING IS THE SOLE PROPERTY OF AZIMUTH MACHINERY. ANY REPRODUCTION IN PART OR AS A WHOLE WITHOUT THE WRITTEN PERMISSION OF AZIMUTH MACHINERY IS PROHIBITED.

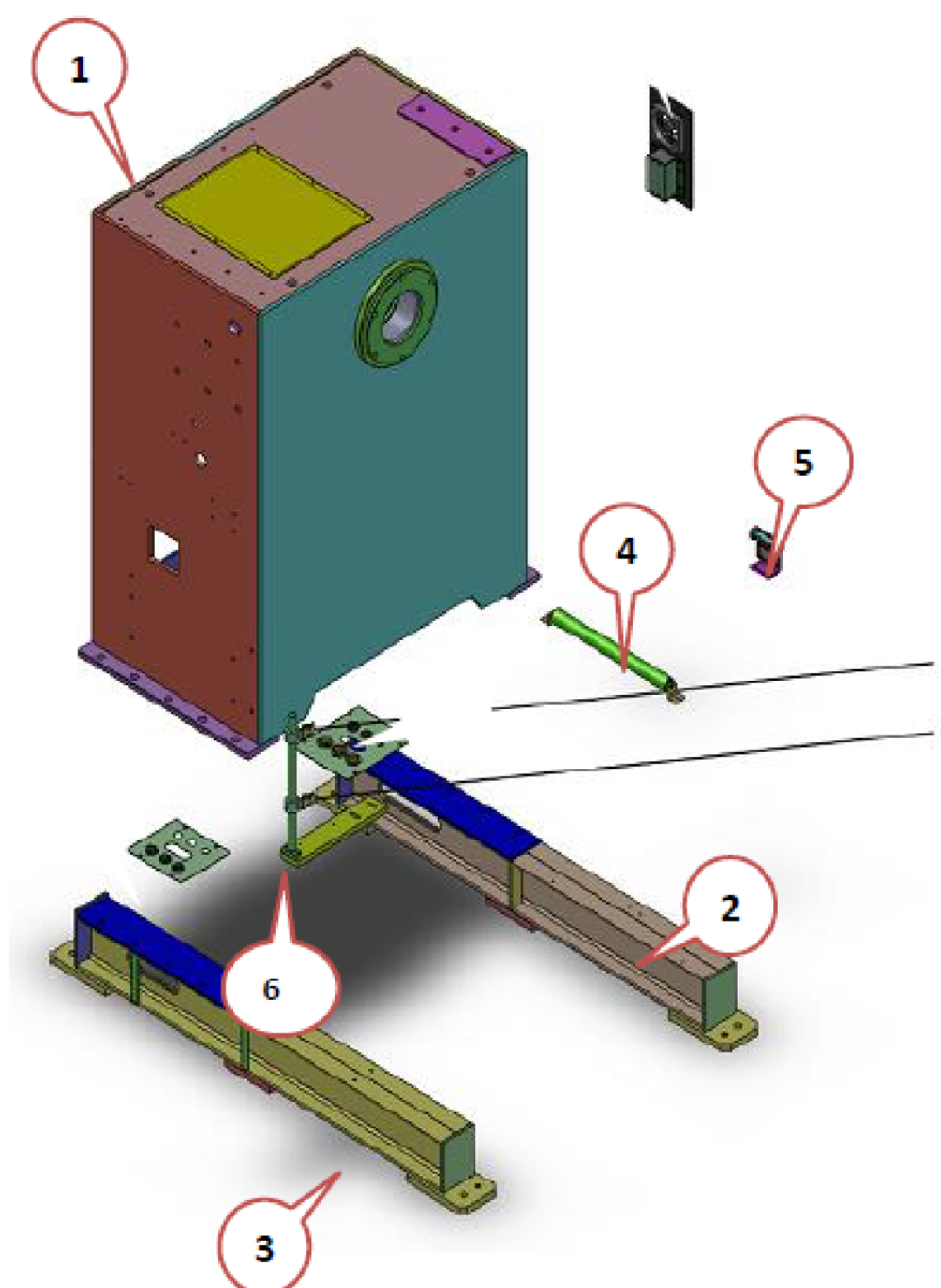

ITEM NO.	PART NO.	DESCRIPTION	QTY.
1	AZ-DHX-XXXX-1001-00	BODY	1
2	AZ-DHX-XXXX-1002-00	LEFT FEET	1
3	AZ-DHX-XXXX-1003-00	RIGHT FEET	1
4	AZ-DHX-XXXX-1004-00	GUIDING ROLLER	1
5	AZ-DHX-XXXX-1005-00	LIFTING ROLLER	1
6	AZ-DHX-XXXX-1006-00	PHOTOELECTRIC SENSOR BRACKET	1

DESCRIPTION
HYDRAULIC DECOILER FRAME ASSEMBLY

PART NO
AZ-DHX-XXXX-1000-XX

DRAWN BY CHARLES LEFEBVRE	SCALE 4:1
DATE 2025-02-20	MATERIAL
RAW MATERIAL	QTY
TREATMENT	WEIGHT

AZIMUTH
 Azimuth Machinery Ltd
 T 450 537 8080
 F 450 532 8081
 www.azimuthpress.com
 6042 Rte. 132, Ste-Catherine
 QC, Canada, J5C 1K6

PROPRIETARY AND CONFIDENTIAL
 THE INFORMATION CONTAINED IN THIS DRAWING IS THE SOLE PROPERTY OF AZIMUTH MACHINERY. ANY REPRODUCTION IN PART OR AS A WHOLE WITHOUT THE WRITTEN PERMISSION OF AZIMUTH MACHINERY IS PROHIBITED.

ITEM NO.	PART NO.	DESCRIPTION	QTY.	ITEM NO.	PART NO.	DESCRIPTION	QTY.
1	AZ-DHX-XXXX-4001-00	TILE PLATE	3	13	AZ-DHX-XXXX-4012-00	FRONT COVER	1
2	AZ-DHX-XXXX-4002-00	EXPANSION BOARD BRACKET	3	14	AZ-DHX-XXXX-2002-00	TIE	1
3	AZ-DHX-XXXX-4003-00	SLIDER	3	15	AZ-DHX-XXXX-2003-00	SUBDIVY OF SPINDLE 16A-40	1
4	AZ-DHX-XXXX-4004-00	HINGE	3	16	AZ-DHX-XXXX-2004-00	ROTARY UNION	1
5	AZ-DHX-XXXX-4005-00	PLATTES OF EXPANSION	1	17	AZ-DHX-XXXX-4013-00	WASHER	3
6	AZ-DHX-XXXX-4006-00	SHORT HINGE	3	18	AZ-DHX-XXXX-4014-00	BLOCK	3
7	AZ-DHX-XXXX-4007-00	LINK (1)	3	19	AZ-DHX-XXXX-2005-00	BRAKE DISC	1
8	AZ-DHX-XXXX-4008-00	LINK (2)	3	20	AZ-DHX-XXXX-2006-00	BEARING PAD	1
9	AZ-DHX-XXXX-4009-00	PLUG	30	21	AZ-DHX-XXXX-2007-00	RISING	1
10	AZ-DHX-XXXX-4010-00	PAD	3	22	AZ-DHX-XXXX-2008-00	TANK	1
11	AZ-DHX-XXXX-2001-00	SPINDLE	1	23	AZ-DHX-XXXX-2007-00	HEX NUT	1
12	AZ-DHX-XXXX-4011-00	GUIDE KEY	3				

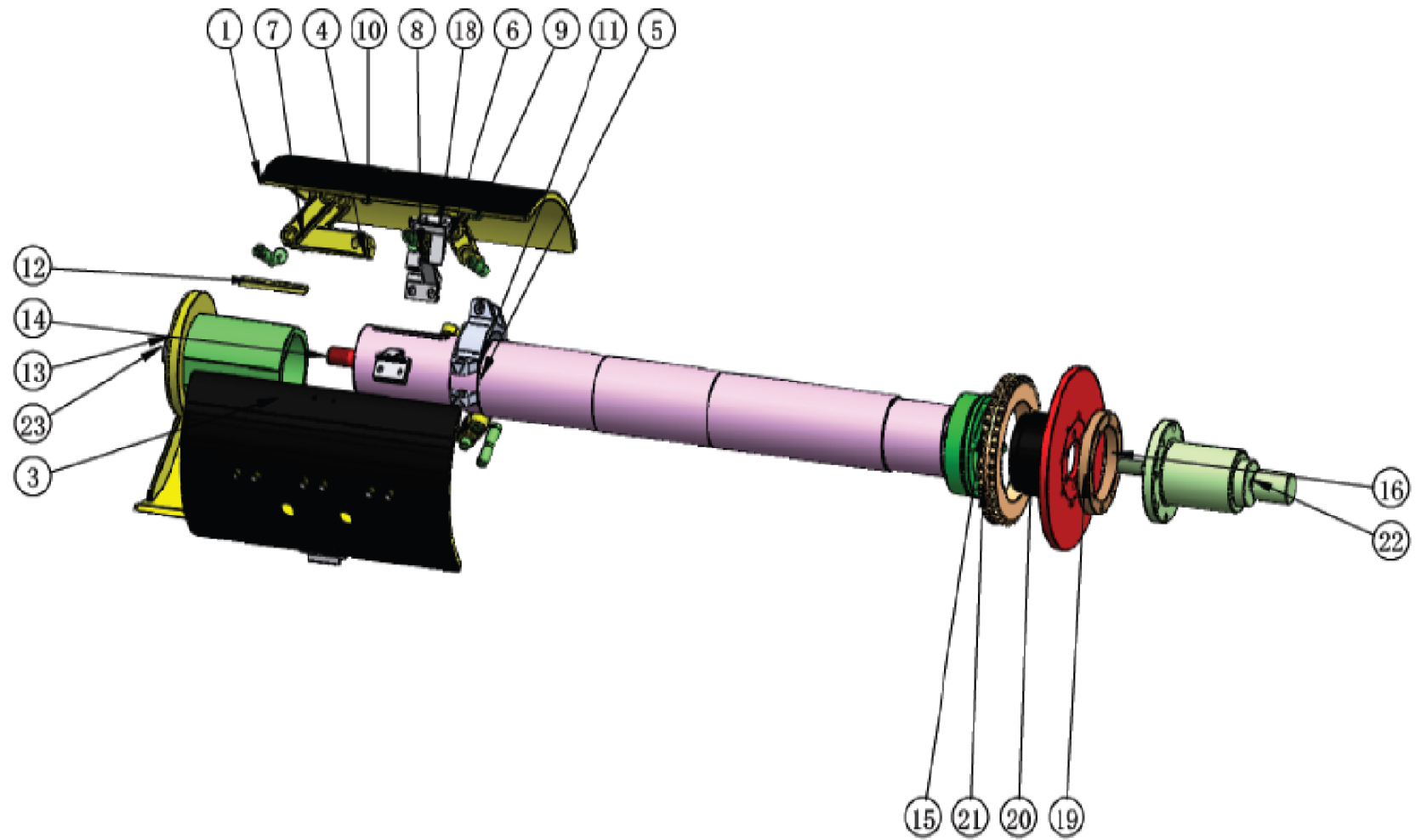

DESCRIPTION
HYDRAULIC DECOILERMANDREL SHAFT &
EXPANSION ASSEMBLY
PART NO
AZ-DHX-XXXX-2000-XX &
AZ-DHX-XXXX-4000-XX

DRAWN BY CHARLES LEFEBVRE	SCALE 4:1
DATE 2025-02-20	MATERIAL
RAW MATERIAL	QTY
TREATMENT	WEIGHT



Azimuth Machinery Ltd
T 450 532 6080
F 450 532 6081
www.azimuthpress.com
6042 Rte. 132, Ste-Catherine
QC, Canada, J5C 1K6

PROPRIETARY AND CONFIDENTIAL
THE INFORMATION CONTAINED IN THIS DRAWING IS THE
SOLE PROPERTY OF AZIMUTH MACHINERY. ANY
REPRODUCTION IN PART OR AS A WHOLE WITHOUT THE
WRITTEN PERMISSION OF AZIMUTH MACHINERY
IS PROHIBITED.

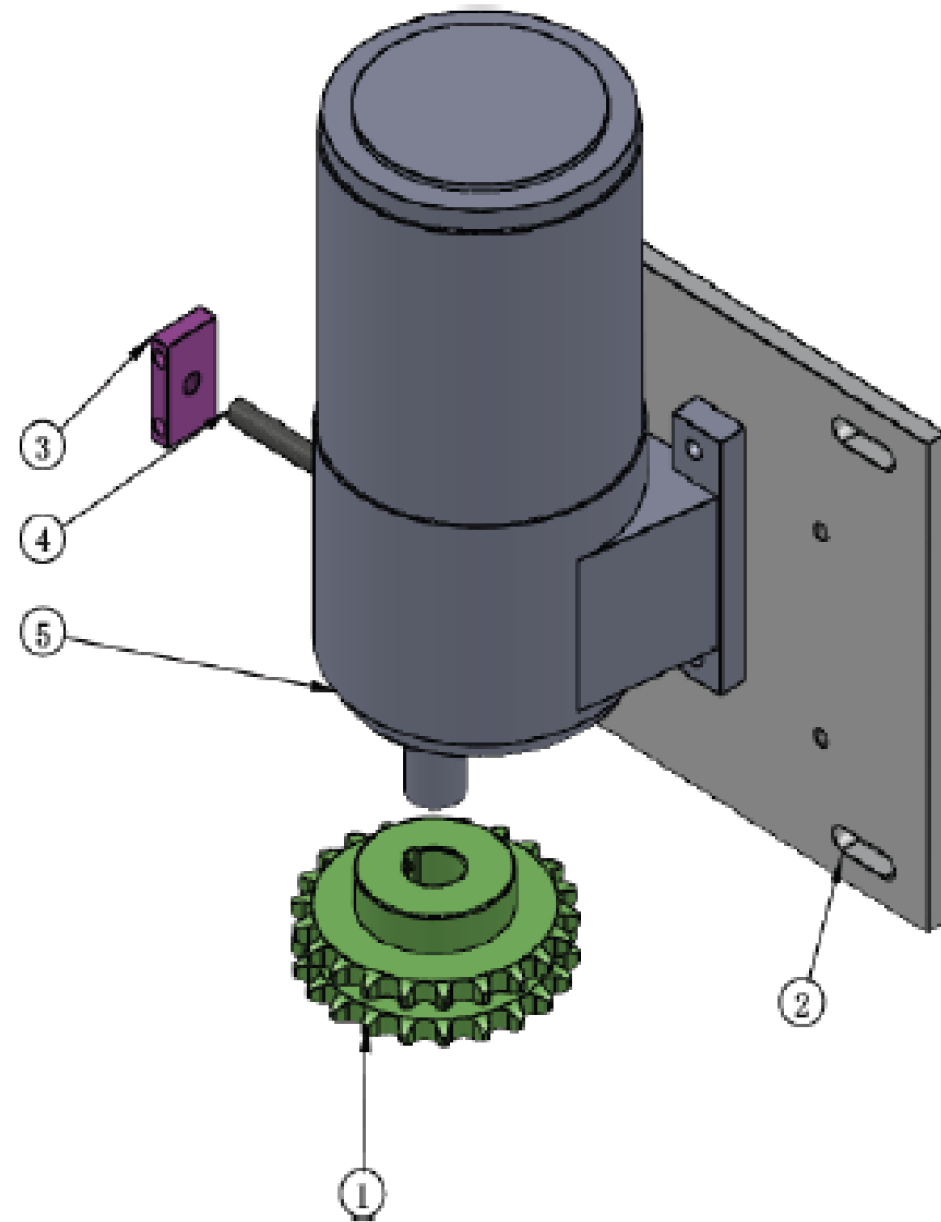

ITEM NO.	PART NO.	DESCRIPTION	QTY.
1	AZ-DHX-XXXX-3001-00	MOTOR SPROCKET	1
2	AZ-DHX-XXXX-3002-00	MOTOR BRACKET	1
3	AZ-DHX-XXXX-3003-00	TENSIONNER BRACKET	1
4	AZ-DHX-XXXX-3004-00	TENSIONNER SCREW	1
5	AZ-DHX-XXXX-3005-00	MOTOR & GEARBOX (MIGHT VARY)	1
6	AZ-DHX-XXXX-3006-00	CHAIN (NOT SHOWN)	1

DESCRIPTION
HYDRAULIC DECOILER MOTOR ASSEMBLY

PART NO
AZ-DHX-XXXX-3000-XX

DRAWN BY CHARLES LEFEBVRE	SCALE 4:1
DATE 2025-02-20	MATERIAL
RAW MATERIAL	QTY
TREATMENT	WEIGHT

AZIMUTH
 Azimuth Machinery Ltd
 T 450 532 8080
 F 450 532 8081
 www.azimuthpress.com
 6042 Rte. 132, Ste-Catherine
 QC, Canada, J5C 1K6

PROPRIETARY AND CONFIDENTIAL
 THE INFORMATION CONTAINED IN THIS DRAWING IS THE SOLE PROPERTY OF AZIMUTH MACHINERY. ANY REPRODUCTION IN PART OR AS A WHOLE WITHOUT THE WRITTEN PERMISSION OF AZIMUTH MACHINERY IS PROHIBITED.

ITEM NO.	PART NO.	DESCRIPTION	QTY.
1	AZ-DHX-XXXX-5100-00	COIL CART UPPER ASSEMBLY	1
2	AZ-DHX-XXXX-5001-00	CYLINDER END COVERT	1
3	AZ-DHX-XXXX-5002-00	PILLAR	4
4	AZ-DHX-XXXX-5003-00	TROLLEY PROTECTIVE COVER	2
5	AZ-DHX-XXXX-5004-00	GUIDE	1
6	AZ-DHX-XXXX-5005-00	TRAILER	1

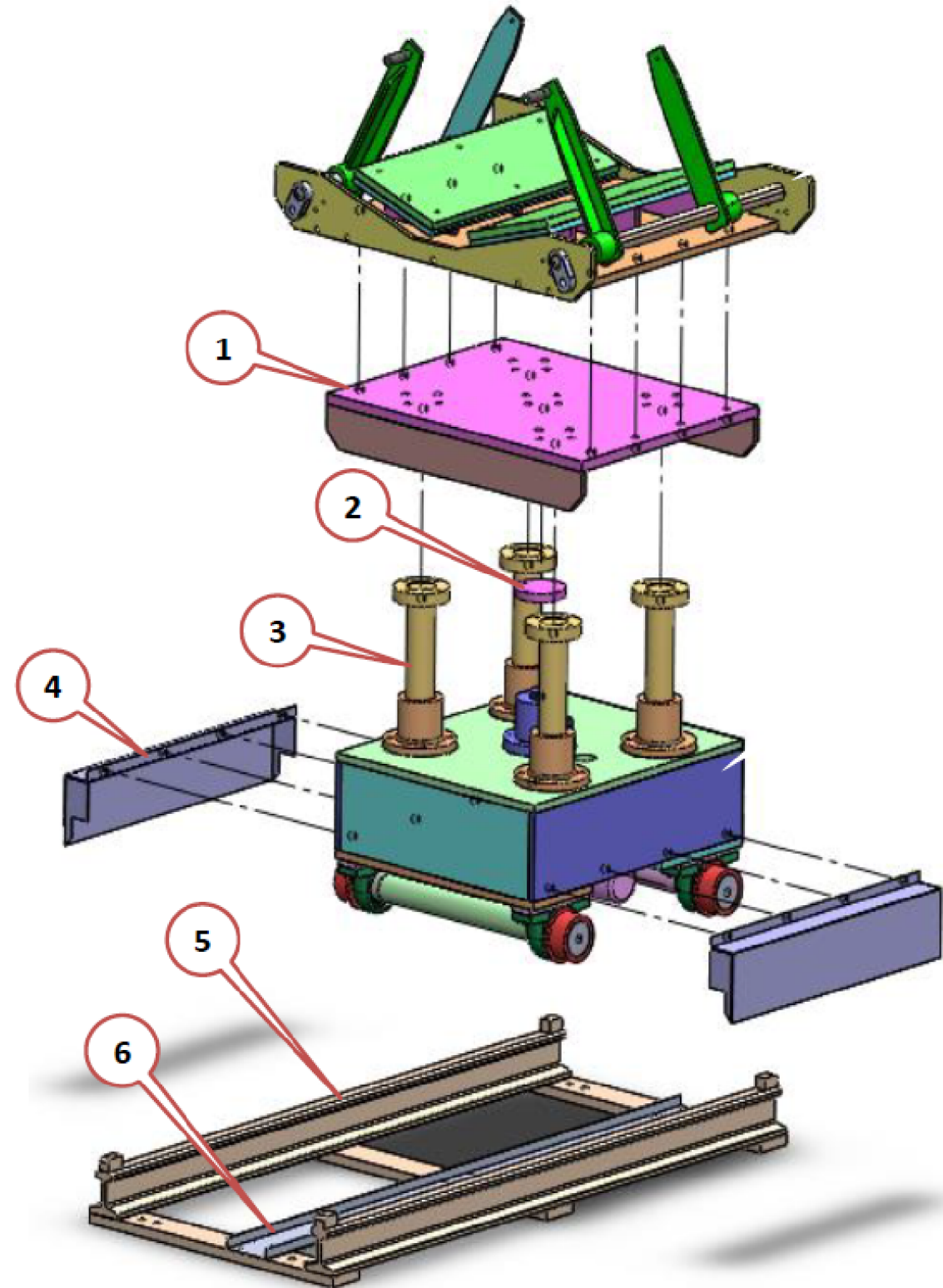

DESCRIPTION	
HYDRAULIC DECOILER CART ASSEMBLY	
PART NO	
AZ-DHX-XXXX-5000-XX	
DRAWN BY	SCALE
CHARLES LEFEBVRE	4:1
DATE	MATERIAL
2025-02-20	
RAW MATERIAL	QTY
TREATMENT	WEIGHT



Azimuth Machinery Ltd.
 T 450 532 6080
 F 450 532 6081
 www.azimuthpress.com
 6042 Rte. 132, Ste-Catherine
 QC, Canada, J5C 1K6

PROPRIETARY AND CONFIDENTIAL

THE INFORMATION CONTAINED IN THIS DRAWING IS THE SOLE PROPERTY OF AZIMUTH MACHINERY. ANY REPRODUCTION IN PART OR AS A WHOLE WITHOUT THE WRITTEN PERMISSION OF AZIMUTH MACHINERY IS PROHIBITED.

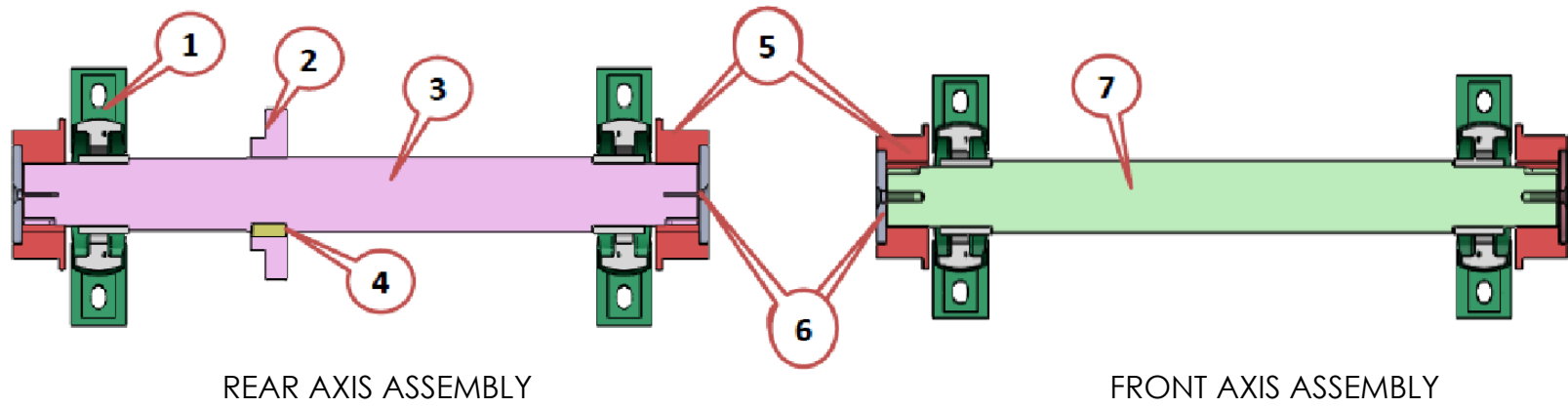

REAR AXIS ASSEMBLY

FRONT AXIS ASSEMBLY

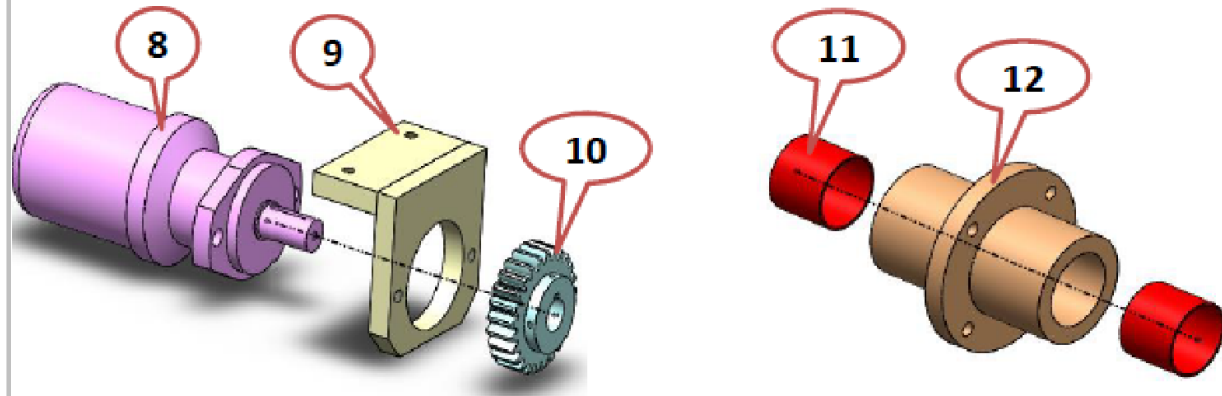

OIL PUMP MOTOR ASSEMBLY

GUIDE SET ASSEMBLY

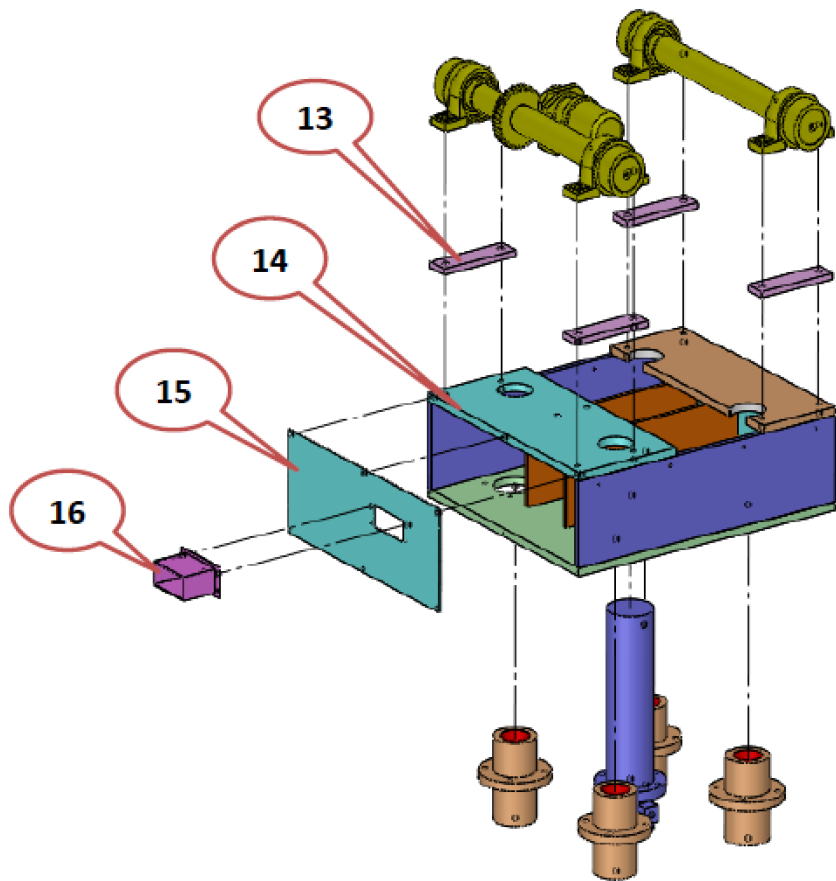

COIL CART MIDDLE ASSEMBLY

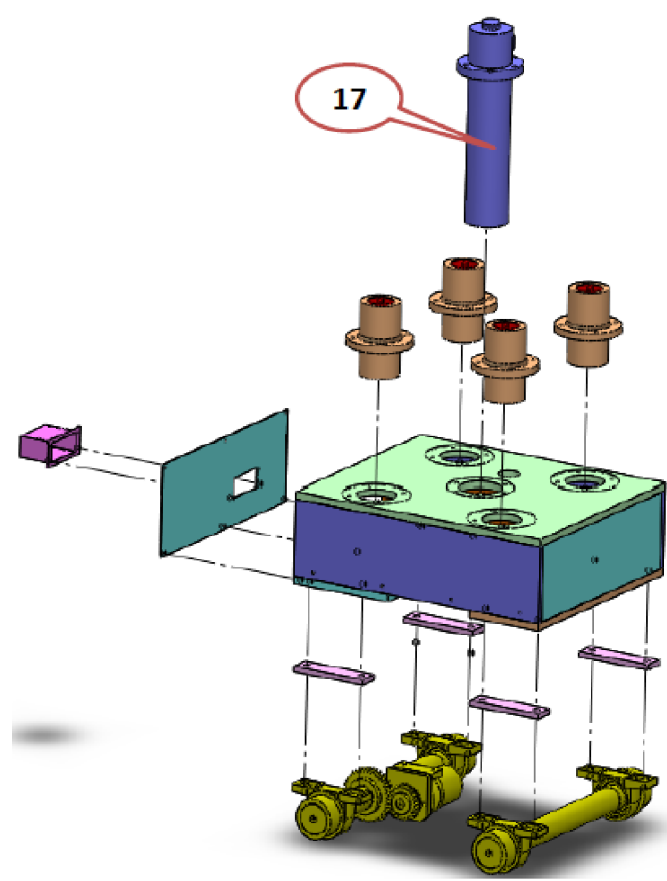

COIL CART CYLINDER ASSEMBLY

ITEM NO.	PART NO.	DESCRIPTION	QTY.
1	AZ-DHX-XXXX-5201-00	STANDING LANDTED BEARING UCP211	4
2	AZ-DHX-XXXX-5202-00	COIL CART GEAR 40 X 3.5	1
3	AZ-DHX-XXXX-5203-00	REAR AXIS	1
4	AZ-DHX-XXXX-5204-00	ORDINARY FLAT KEY 18 X 40	1
5	AZ-DHX-XXXX-5205-00	WHEEL	4
6	AZ-DHX-XXXX-5206-00	WHEEL COVER	4
7	AZ-DHX-XXXX-5207-00	FRONT AXIS	1
8	AZ-DHX-XXXX-5301-00	HYDRAULIC MOTOR BM-R80-400	1
9	AZ-DHX-XXXX-5302-00	OIL PUMP MOTOR FIXED SEAT	1
10	AZ-DHX-XXXX-5303-00	MOTOR GEAR 25 X 3.5	1
11	AZ-DHX-XXXX-5401-00	SF-1X BEARINGS (707560)	8
12	AZ-DHX-XXXX-5402-00	GUIDES	4
13	AZ-DHX-XXXX-5501-00	PAD	4
14	AZ-DHX-XXXX-5502-00	A1 FRAME WELDING	1
15	AZ-DHX-XXXX-5503-00	A2 COIR CART BOARD	1
16	AZ-DHX-XXXX-5504-00	DRAG CHAIN FIXED BOARD	1
17	AZ-DHX-XXXX-5006-00	LIFTING OIL CYLINDER 100 X 360	

DESCRIPTION
HYDRAULIC DECOILER CART ASSEMBLY

PART NO
AZ-DHX-XXXX-5000-XX

DRAWN BY CHARLES LEFEVRE	SCALE 4:1
DATE 2025-02-20	MATERIAL
RAW MATERIAL	QTY
TREATMENT	WEIGHT



Azimuth Machinery Ltd.
T 450 532 6080
F 450 532 6081
www.azimuthpress.com
6042 Rte. 132, Ste-Catherine
QC, Canada, J5C 1K6

PROPRIETARY AND CONFIDENTIAL

THE INFORMATION CONTAINED IN THIS DRAWING IS THE SOLE PROPERTY OF AZIMUTH MACHINERY. ANY REPRODUCTION IN PART OR AS A WHOLE WITHOUT THE WRITTEN PERMISSION OF AZIMUTH MACHINERY IS PROHIBITED.

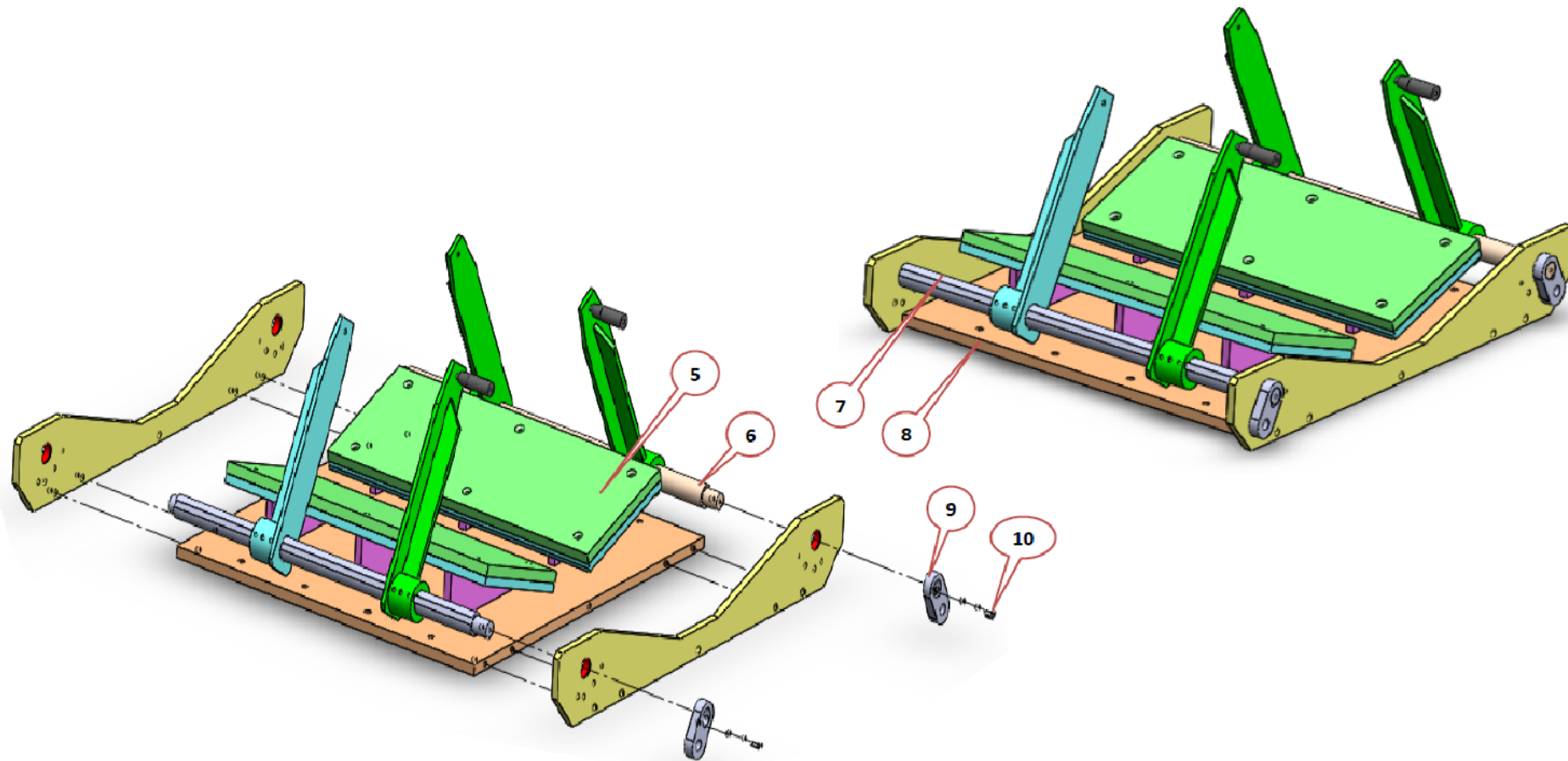
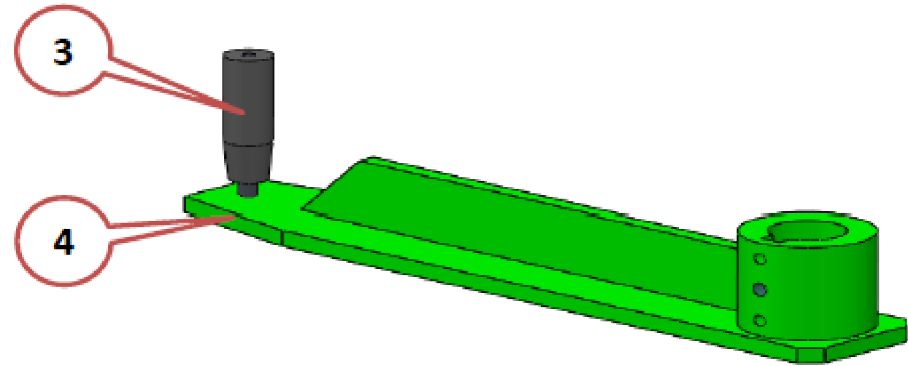
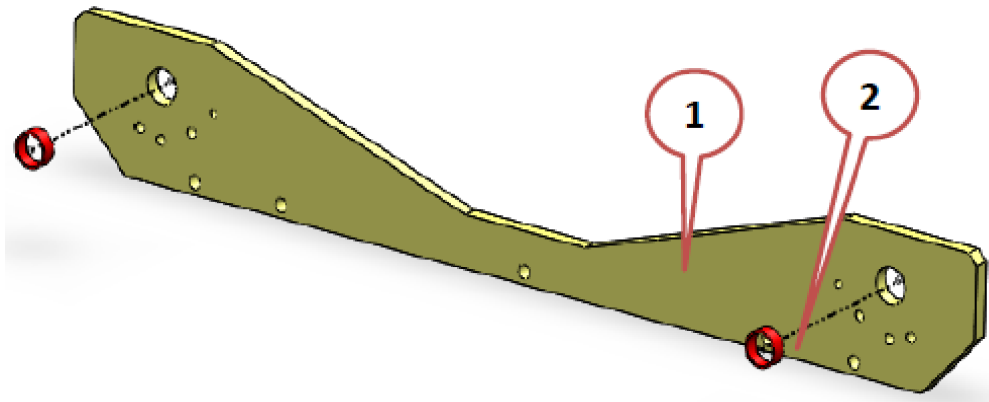

ITEM NO.	PART NO.	DESCRIPTION	QTY.
1	AZ-DHX-XXXX-5101-00	LIMITING PLATE	2
2	AZ-DHX-XXXX-5102-00	SF-1X BEARINGS (303415)	4
3	AZ-DHX-XXXX-5103-00	HANDLE M10-100	4
4	AZ-DHX-XXXX-5104-00	HANDLE LIMITING PLATE	4
5	AZ-DHX-XXXX-5105-00	V-SHAPED RUBBER PLATE	2
6	AZ-DHX-XXXX-5106-00	SHAFT (2)	1
7	AZ-DHX-XXXX-5107-00	SHAFT (1)	1
8	AZ-DHX-XXXX-5108-00	V-SHAPED SEAT WELDING	1
9	AZ-DHX-XXXX-5109-00	HANLDE	2
10	AZ-DHX-XXXX-5110-00	WEDGE KEY 8X20	2

DESCRIPTION	
HYDRAULIC DECOILER CART ASSEMBLY	
PART NO	
AZ-DHX-XXXX-5100-XX	
DRAWN BY	SCALE
CHARLES LEFEVRE	4:1
DATE	MATERIAL
2025-02-20	
RAW MATERIAL	QTY
TREATMENT	WEIGHT



Azimuth Machinery Ltd
 T 450 537 6080
 F 450 532 6081
 www.azimuthpress.com
 6042 Rte. 132, Ste-Catherine
 QC, Canada, J5C 1G6

PROPRIETARY AND CONFIDENTIAL

THE INFORMATION CONTAINED IN THIS DRAWING IS THE SOLE PROPERTY OF AZIMUTH MACHINERY. ANY REPRODUCTION IN PART OR AS A WHOLE WITHOUT THE WRITTEN PERMISSION OF AZIMUTH MACHINERY IS PROHIBITED.

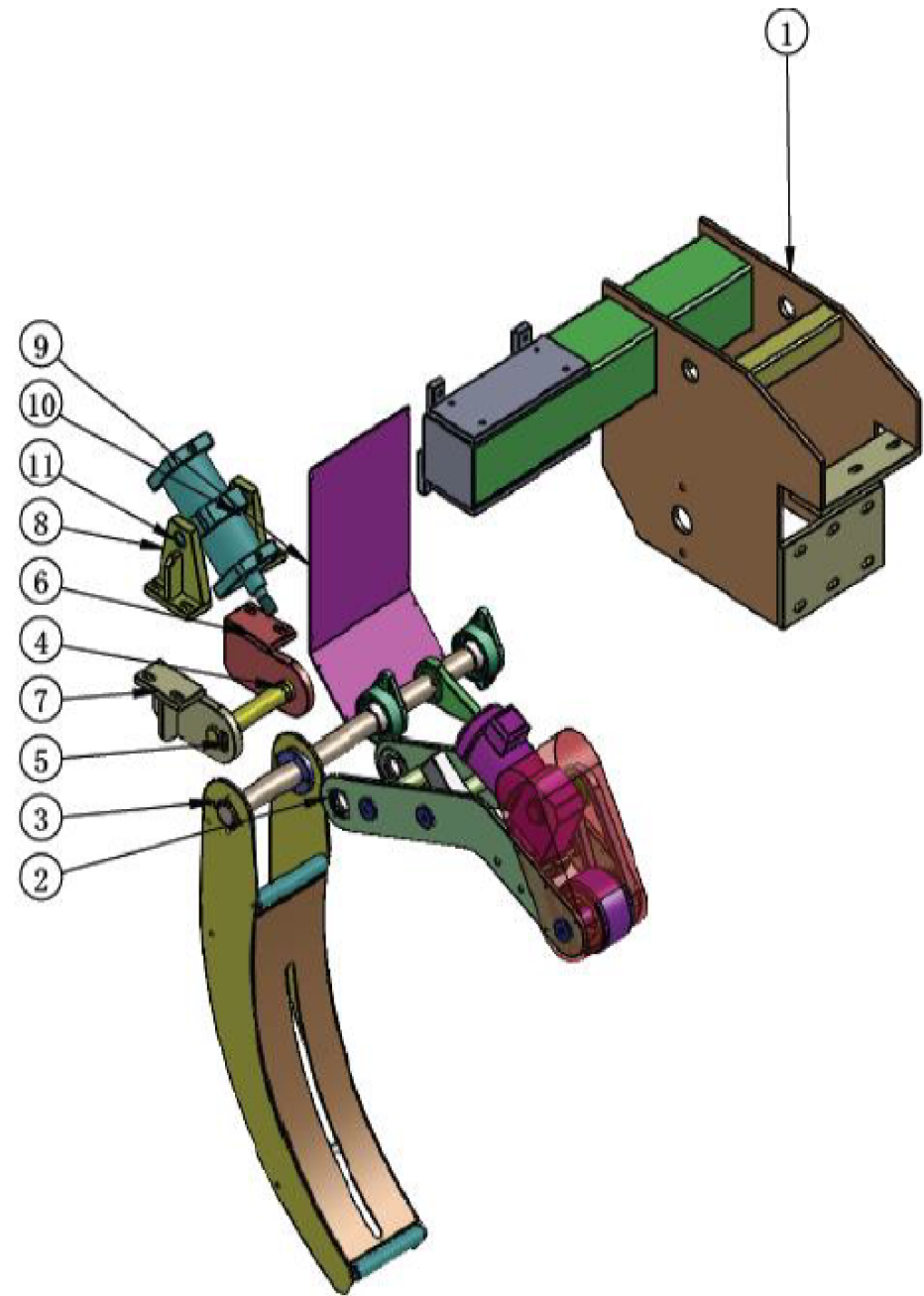

ITEM NO.	PART NO.	DESCRIPTION	QTY.
1	AZ-DHX-XXXX-7101-00	PRESSING ARM SHELF	1
2	AZ-DHX-XXXX-7102-00	PRESSING ARM	1
3	AZ-DHX-XXXX-7201-00	SUPPORTING ARM	1
4	AZ-DHX-XXXX-7202-00	SUPPORT SHAFT	1
5	AZ-DHX-XXXX-7203-00	STOPPER	1
6	AZ-DHX-XXXX-7204-00	BEARING SEAT 1	1
7	AZ-DHX-XXXX-7205-00	BEARING SEAT 2	1
8	AZ-DHX-XXXX-7103-00	AIR CYLINDER BASE	2
9	AZ-DHX-XXXX-7104-00	SUPPORTING ARM SHELF	1
10	AZ-DHX-XXXX-7105-00	AIR CYLINDER	1
11	AZ-DHX-XXXX-7106-00	FLANGED COPPER SLEEVE	2

DESCRIPTION	
HYDRAULIC DECOILER PRESSURE & SWING ARM ASSEMBLY	
PART NO AZ-DHX-XXXX-7100-XX & AZ-DHX-XXXX-7200-XX	
DRAWN BY CHARLES LEFEBVRE	SCALE 4:1
DATE 2025-02-20	MATERIAL
RAW MATERIAL	QTY
TREATMENT	WEIGHT
 <p>Azimuth Machinery Ltd T 450 532 8080 F 450 532 8081 www.azimuthpress.com 6042 Rte. 132, Ste-Catherine QC, Canada, J5C 1K6</p>	
<p>PROPRIETARY AND CONFIDENTIAL</p> <p>THE INFORMATION CONTAINED IN THIS DRAWING IS THE SOLE PROPERTY OF AZIMUTH MACHINERY. ANY REPRODUCTION IN PART OR AS A WHOLE WITHOUT THE WRITTEN PERMISSION OF AZIMUTH MACHINERY IS PROHIBITED.</p>	

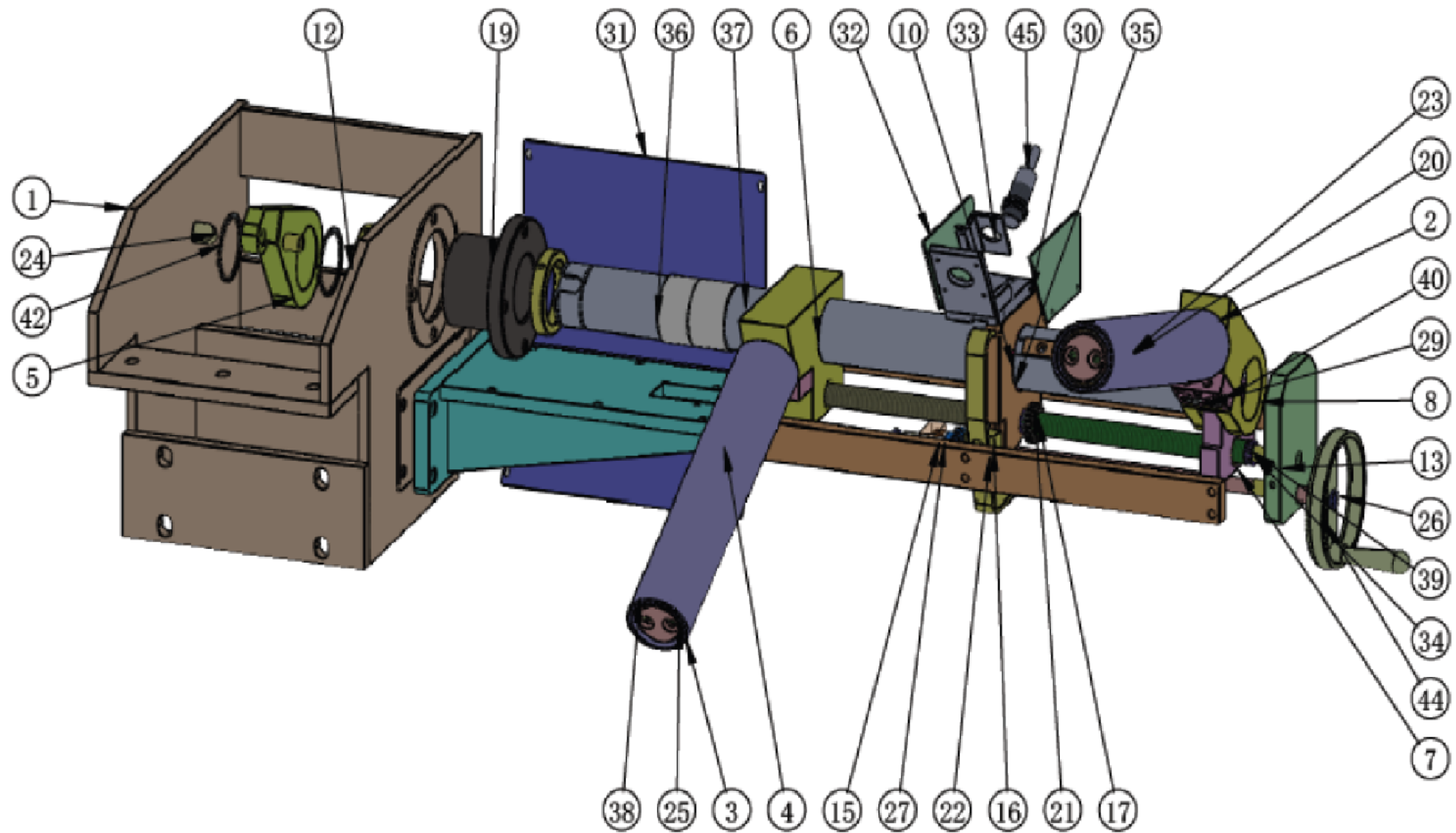

DESCRIPTION	
HYDRAULIC DECOILER COIL KEEPER ASSEMBLY	
PART NO	
AZ-DHX-XXXX-7300-XX	
DRAWN BY	SCALE
CHARLES LEFEBVRE	4:1
DATE	MATERIAL
2025-02-20	
RAW MATERIAL	QTY
TREATMENT	WEIGHT



Azimuth Machinery Ltd
 T 450 532 6080
 F 450 532 6081
 www.azimuthpress.com
 6042 Rte. 132, Ste-Catherine
 QC, Canada, J5C 1K6

PROPRIETARY AND CONFIDENTIAL

THE INFORMATION CONTAINED IN THIS DRAWING IS THE SOLE PROPERTY OF AZIMUTH MACHINERY. ANY REPRODUCTION IN PART OR AS A WHOLE WITHOUT THE WRITTEN PERMISSION OF AZIMUTH MACHINERY IS PROHIBITED.

ITEM NO.	PART NO.	DESCRIPTION	QTY.	ITEM NO.	PART NO.	DESCRIPTION	QTY.
1	AZ-DHX-XXXX-7301-00	RESTRICTED SEAT	1	27	AZ-DHX-XXXX-7327-00	RIGHT-TONE GEAR (2)	1
2	AZ-DHX-XXXX-7302-00	LIMITED ROLLER SHAFT	2	28	AZ-DHX-XXXX-7328-00	LIMITED ROLLER SECTOR SALES AXIS	1
3	AZ-DHX-XXXX-7303-00	RESTRICTED ROLLER	2	29	AZ-DHX-XXXX-7329-00	LIMITED BEARING INSTALLATION SEAT	1
4	AZ-DHX-XXXX-7304-00	LIMIT ROLLER FRAME	1	30	AZ-DHX-XXXX-7330-00	LIGHT INDUCTION	1
5	AZ-DHX-XXXX-7305-00	LIMITED TANK ARM	1	31	AZ-DHX-XXXX-7331-00	BLOCK	1
6	AZ-DHX-XXXX-7306-00	REAR-LIMITED ROLLER SEAT	1	32	AZ-DHX-XXXX-7332-00	PROTECTION BOARD	1
7	AZ-DHX-XXXX-7307-00	FRONT SNAIL BOARD	1	33	AZ-DHX-XXXX-7333-00	FIELD SENSOR INSTALLATION RACK	1
8	AZ-DHX-XXXX-7308-00	RESTRICTED ROLLER SEAT	1	34	AZ-DHX-XXXX-7334-00	SF-1X BEARING 202325	1
9	AZ-DHX-XXXX-7309-00	REAR SNAIL BOARD	1	35	AZ-DHX-XXXX-7335-00	SF-1X BEARING 909525	1
10	AZ-DHX-XXXX-7310-00	INTERMEDIATE LIMIT SEAT	1	36	AZ-DHX-XXXX-7336-00	SF-1X BEARING 909550	1
11	AZ-DHX-XXXX-7311-00	ADJUSTMENT POLE	1	37	AZ-DHX-XXXX-7337-00	SF-1X BEARING 909560	1
12	AZ-DHX-XXXX-7312-00	LIMIT CIRCLE	1	38	AZ-DHX-XXXX-7338-00	DEEP GROOVE BALL BEARINGS 6813-2Z	1
13	AZ-DHX-XXXX-7313-00	LIMIT PLATE	1	39	AZ-DHX-XXXX-7339-00	THRUST BALL BEARINGS 51104	1
14	AZ-DHX-XXXX-7314-00	SCREW	1	40	AZ-DHX-XXXX-7340-00	DEEP GROOVE BALL BEARINGS 6201-2Z	1
15	AZ-DHX-XXXX-7315-00	GEAR	1	41	AZ-DHX-XXXX-7341-00	SHAFT CARD SPRING	1
16	AZ-DHX-XXXX-731600	CONNECTING PLATE	1	42	AZ-DHX-XXXX-7342-00	SHAFT CARD SPRING	1
17	AZ-DHX-XXXX-7317-00	RIGHT ROTATION SCREW	1	43	AZ-DHX-XXXX-7343-00	FLAT KEY A	1
18	AZ-DHX-XXXX-7318-00	LEVAN SCREW (T-TYPE)	1	44	AZ-DHX-XXXX-7344-00	TWO-WHEEL POKE HANDLE	1
19	AZ-DHX-XXXX-7319-00	LIMITED ARM AXLE	1	45	AZ-DHX-XXXX-7345-00	ROUND HEAD LASER RANGING SENSOR	1
20	AZ-DHX-XXXX-7320-00	MAIN AXIS OF LIMITED ARM	1				
21	AZ-DHX-XXXX-7321-00	RIGHT-LEVEL GEAR (1)	1				
22	AZ-DHX-XXXX-7322-00	SHOCK	1				
23	AZ-DHX-XXXX-7323-00	LIMITED ARM GUIDE KEY	1				
24	AZ-DHX-XXXX-7324-00	LIMITED ARM FLAT KEY	1				
25	AZ-DHX-XXXX-7325-00	BAFFLE	1				
26	AZ-DHX-XXXX-7326-00	PAD	1				

DESCRIPTION	
HYDRAULIC DECOILER COIL KEEPER ASSEMBLY	
PART NO	
AZ-DHX-XXXX-7300-XX	
DRAWN BY CHARLES LEFEBVRE	SCALE 4:1
DATE 2025-02-20	MATERIAL
RAW MATERIAL	QTY
TREATMENT	WEIGHT
	
Azimuth Machinery Ltd T 450 537 6080 F 450 532 8081 www.azimuthpress.com 6042 Rte. 132, Ste-Catherine QC, Canada, J5C 1W6	
PROPRIETARY AND CONFIDENTIAL THE INFORMATION CONTAINED IN THIS DRAWING IS THE SOLE PROPERTY OF AZIMUTH MACHINERY. ANY REPRODUCTION IN PART OR AS A WHOLE WITHOUT THE WRITTEN PERMISSION OF AZIMUTH MACHINERY IS PROHIBITED.	