

# PASS LINE MIN. AND MAX.

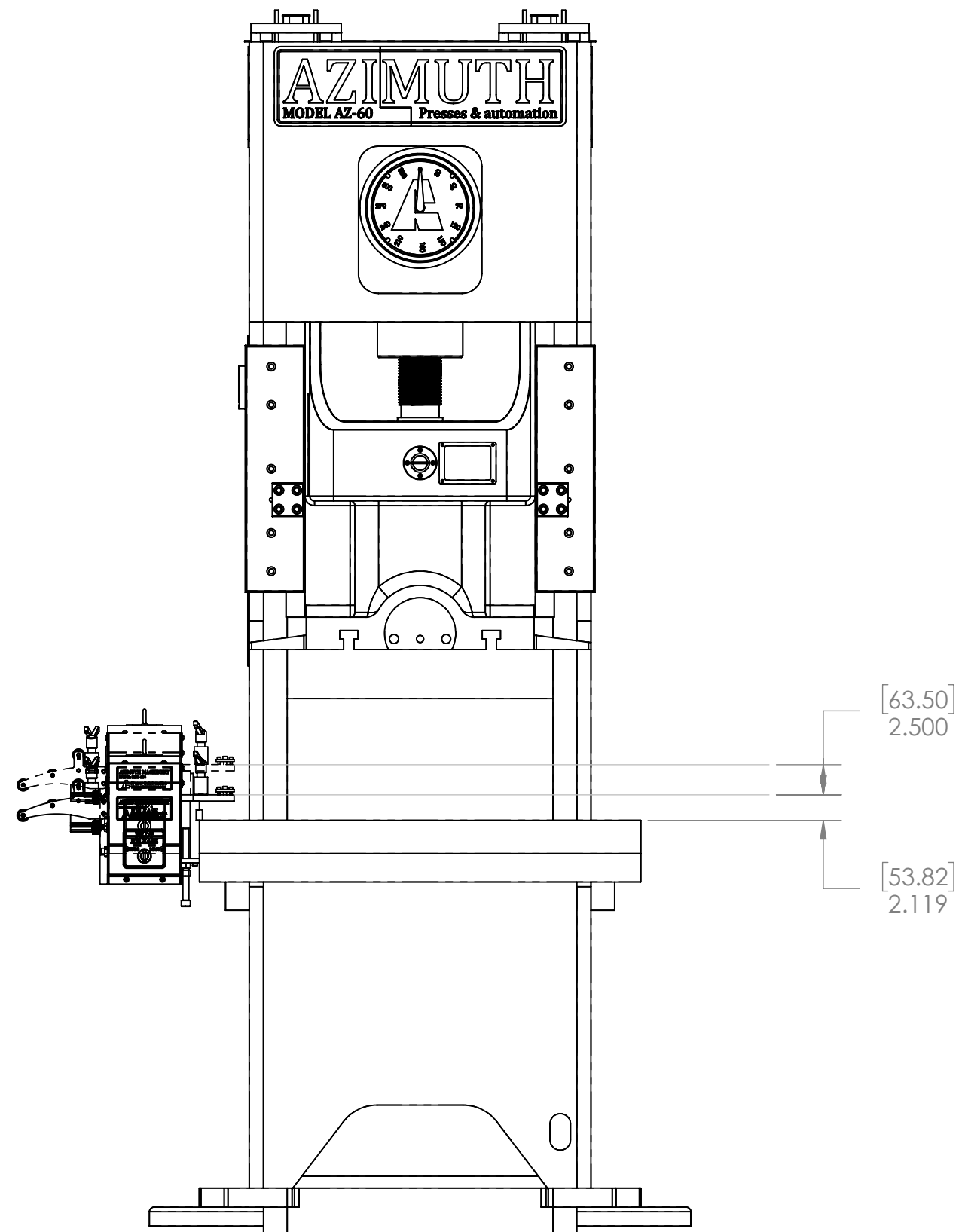

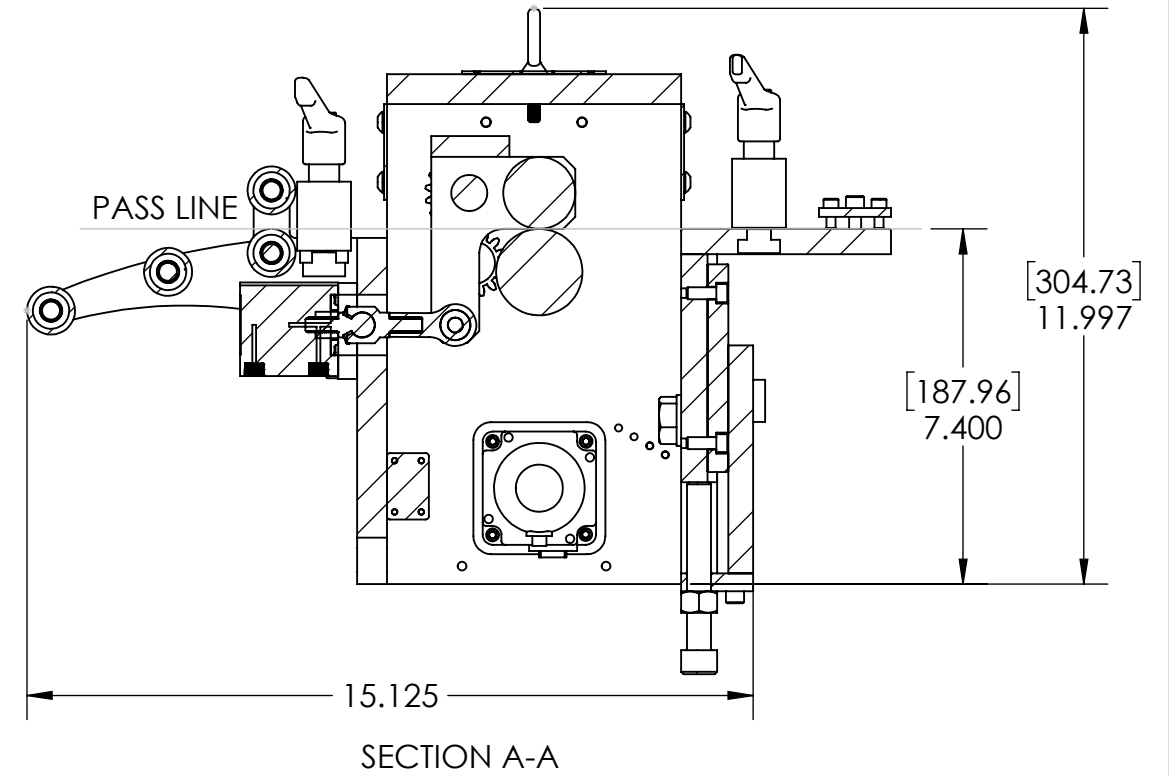

NOTE : BREAK ALL SHARP EDGES

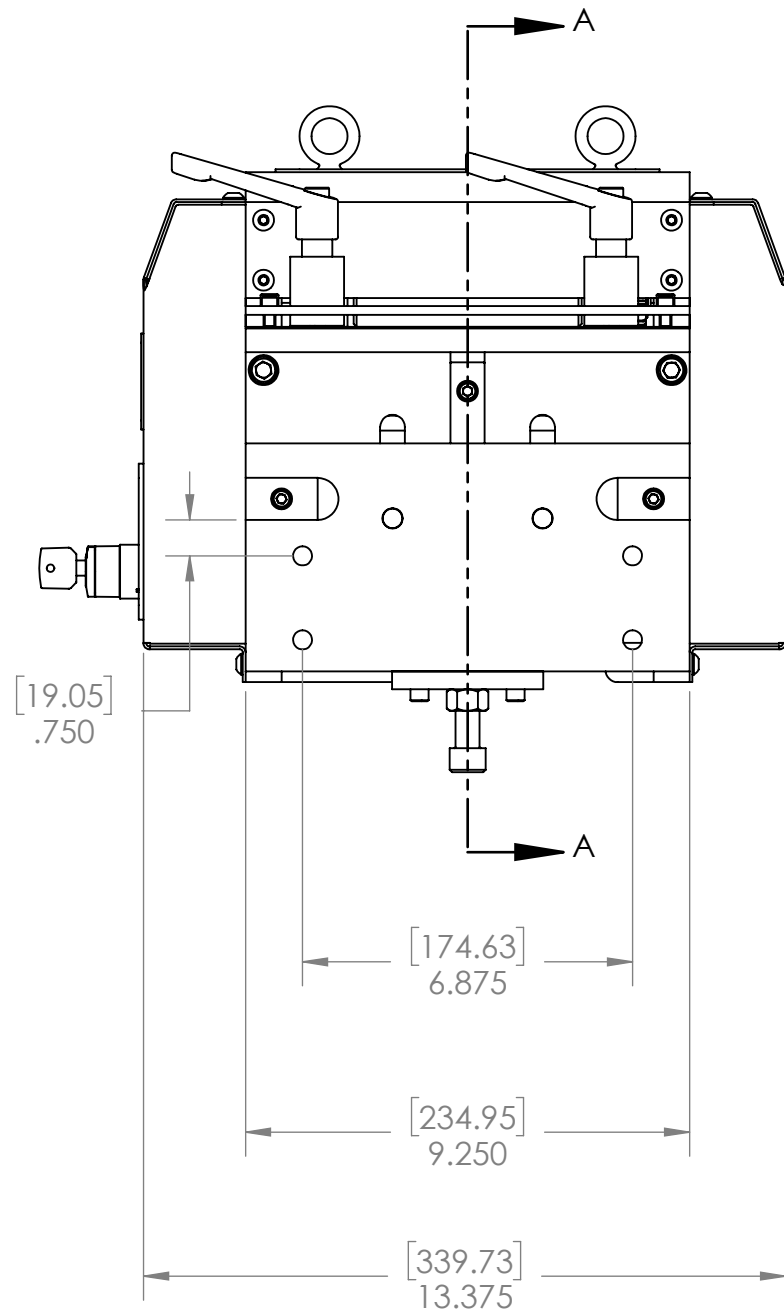
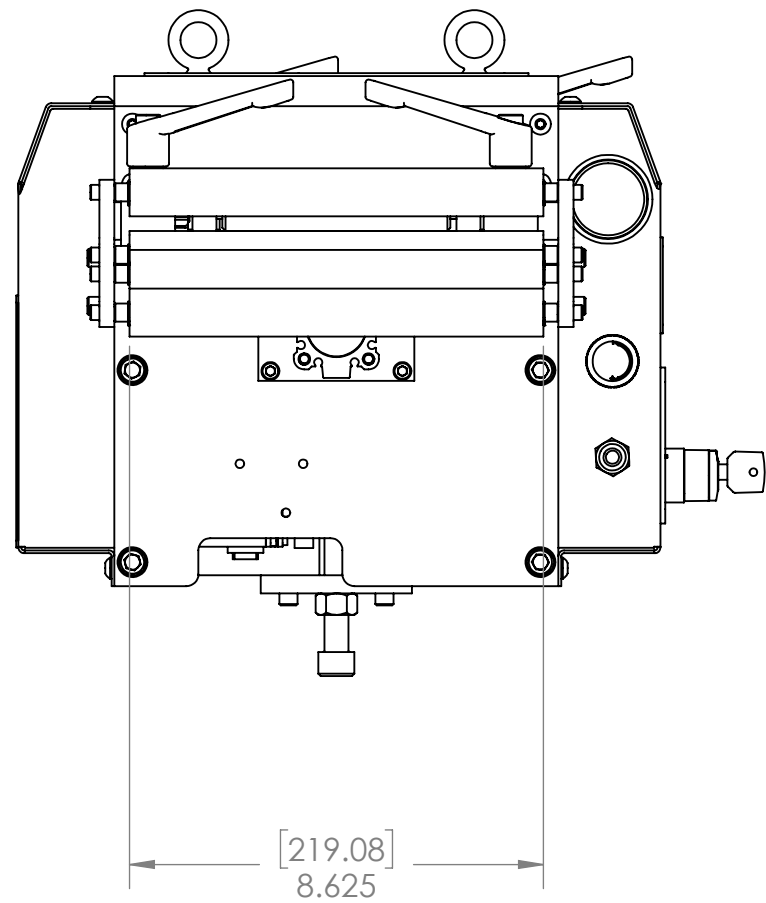
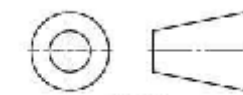

DIMENSIONS ARE IN INCHES  
 TOLERANCES :  
 ANGLES : ±1°  
 FRACTIONAL ±1/32  
 TWO PLACE DECIMAL ±.01  
 THREE PLACE DECIMAL ±.005  
 FOUR PLACE DECIMAL ±.001

DESCRIPTION	
FEEDER AZ-MINI-100	
PART NO	
MINI-100-0000-00	
DRAWN BY	SCALE
ALICE DENIS	1:8
DATE	MATERIAL
4/17/2024	
RAW MATERIAL	QTY
	1
TREATMENT	WEIGHT

**AZIMUTH**  
 Azimuth Machinery Ltd  
 T 450 532 8080  
 F 450 532 8081  
 www.azimuthpress.com  
 6042 Rte. 132, Ste-Catherine  
 QC, Canada, J5C 1K6

**PROPRIETARY AND CONFIDENTIAL**  
 THE INFORMATION CONTAINED IN THIS DRAWING IS THE SOLE PROPERTY OF AZIMUTH MACHINERY. ANY REPRODUCTION IN PART OR AS A WHOLE WITHOUT THE WRITTEN PERMISSION OF AZIMUTH MACHINERY IS PROHIBITED.

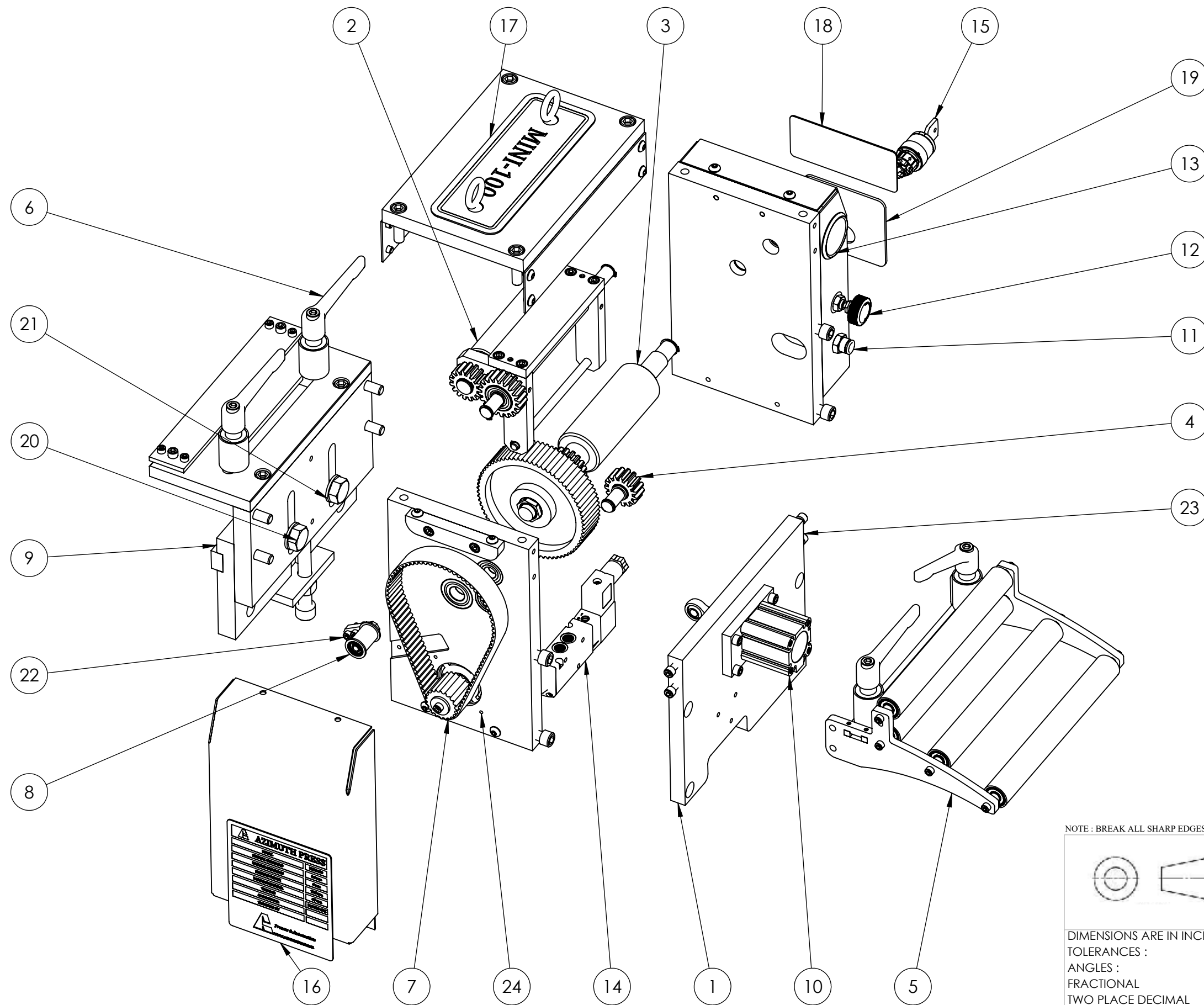

NOTE : BREAK ALL SHARP EDGES



DIMENSIONS ARE IN INCHES  
 TOLERANCES :  
 ANGLES :  $\pm 1^\circ$   
 FRACTIONAL  $\pm 1/32$   
 TWO PLACE DECIMAL  $\pm .01$   
 THREE PLACE DECIMAL  $\pm .005$   
 FOUR PLACE DECIMAL  $\pm .001$

DESCRIPTION	
FEEDER AZ-MINI-100	
PART NO	
MINI-100-0000-00	
DRAWN BY	SCALE
ALICE DENIS	1:8
DATE	MATERIAL
4/17/2024	
RAW MATERIAL	QTY
	1
TREATMENT	WEIGHT



Azimuth Machinery Ltd  
 T 450 532 6080  
 F 450 532 6081  
 www.azimuthpress.com  
 6042 Rte. 132, Ste-Catherine  
 QC, Canada, J5C 1K6

**PROPRIETARY AND CONFIDENTIAL**  
 THE INFORMATION CONTAINED IN THIS DRAWING IS THE SOLE PROPERTY OF AZIMUTH MACHINERY. ANY REPRODUCTION IN PART OR AS A WHOLE WITHOUT THE WRITTEN PERMISSION OF AZIMUTH MACHINERY IS PROHIBITED.

ITEM NO.	PART NUMBER	DESCRIPTION	QTY.
1	MINI-100-1000-00	FRAME	1
2	MINI-100-2000-00	CRANKSHAFT ASSEMBLY	1
3	MINI-100-3000-00	COUPLING SHAFT	1
4	MINI-100-3100-00	SMALL GEAR ASSEMBLY	1
5	MINI-100-4000-00	ROLLER ASSEMBLY	1
6	MINI-100-5000-00	WIDTH LIMITER	4
7	MINI-100-6000-00	MOTOR	1
8	MINI-100-7000-00	TENSIONER	1
9	MINI-100-8000-00	ADJUSTING PLATE	1
10	MINI-100-10000-00	ADJUSTING CYLINDER FOR THICKNESS	1
11	MINI-100-11001-00	AIR CONNECTOR	1
12	MINI-100-11002-00	MINI HIGH PRECISION REGULATOR	1
13	MINI-100-11003-00	SINGLE SCALE PRESSURE GAUGE WITH STEEL CASE	1
14	MINI-100-11004-00	AIR DIRECTIONAL CONTROL VALVE	1
15	MINI-100-11005-00	KEY SWITCH 2 POSITIONS	1
16	MINI-100-12001-00	SPECIFICATIONS PLATE	1
17	MINI-100-12002-00	TOP DECO PLATE	1
18	MINI-100-12003-00	FEEDER SIDE DECO PLATE	1
19	MINI-100-12004-00	PILOT RELEASE PLATE	1
20	HHBOLT 0.5000-13x1.5x1-N		2
21	Preferred Narrow FW 0.5		2
22	HX-SHCS 0.19-24x0.625x0.625-N		2
23	HX-SHCS 0.25-28x0.625x0.625-N		4
24	HX-SHCS 0.164-32x0.5x0.5-N		4

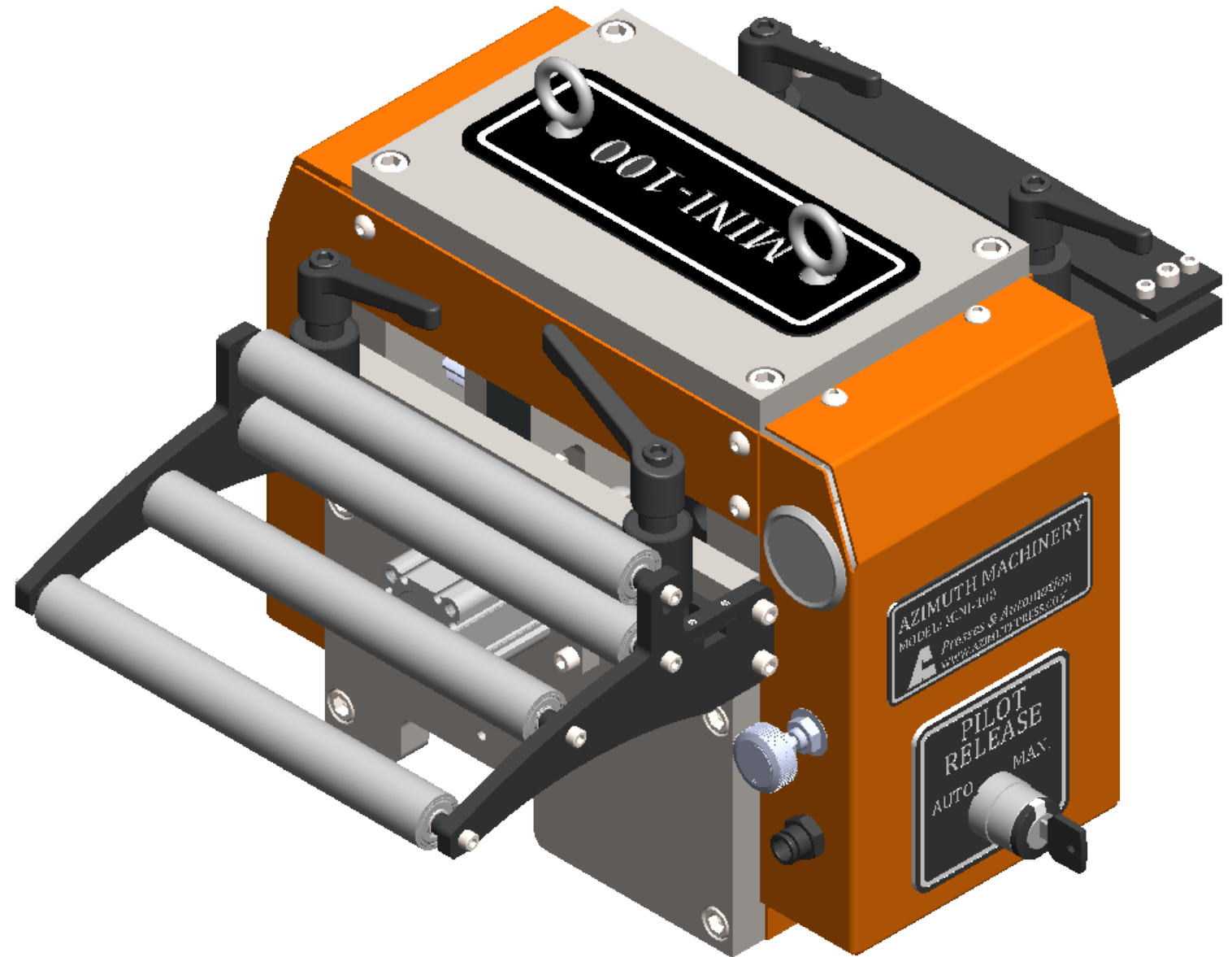

DESCRIPTION	
FEEDER AZ-MINI-100	
PART NO	
MINI-100-0000-00	
DRAWN BY	SCALE
ALICE DENIS	1:8
DATE	MATERIAL
4/17/2024	
RAW MATERIAL	QTY
	1
TREATMENT	WEIGHT

NOTE : BREAK ALL SHARP EDGES

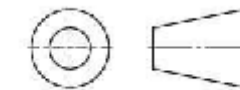

DIMENSIONS ARE IN INCHES  
TOLERANCES :  
ANGLES : ±1°  
FRACTIONAL ±1/32  
TWO PLACE DECIMAL ±.01  
THREE PLACE DECIMAL ±.005  
FOUR PLACE DECIMAL ±.001

**AZIMUTH**  
Azimuth Machinery Ltd  
T 450 532 6080  
F 450 532 6081  
www.azimuthpress.com  
6042 Rte. 132, Ste-Catherine  
QC, Canada, J5C 1K6

**PROPRIETARY AND CONFIDENTIAL**  
THE INFORMATION CONTAINED IN THIS DRAWING IS THE SOLE PROPERTY OF AZIMUTH MACHINERY. ANY REPRODUCTION IN PART OR AS A WHOLE WITHOUT THE WRITTEN PERMISSION OF AZIMUTH MACHINERY IS PROHIBITED.